

# Plastic Modular Belt

Series **uni Flex L-ASB** Type **47% Open (Radius 1.6)**

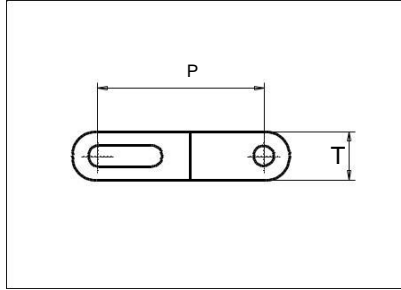
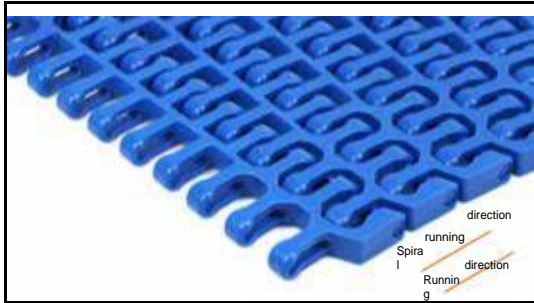

Sideflexing belt  
 Nominal pitch: 50.8 mm (2.00 in)  
 Surface type: Flat  
 Surface opening: 47%  
 Backflex radius: 100.0 mm (3.94 in)  
 Pin diameter: 6.0 mm (0.24 in)  
 Min. inside radius: 1.6 x belt width

Belt material & color	POM-D	PP	mm	in
	W	W		
Pin and lock material & color	PA6.6		P (Nominal)	
			T	
			50.8	2.00
			15.0	0.59

Non standard material and color: See uni Material and Color Overview.  
 Alternative pin and lock systems and materials: Contact Customer Service.

Belt width		Permissible tensile force (Belt/pin material)								Belt weight (Belt/pin material)				*Min. No. drive sprocket per shaft	Number of wear strips (Min. No.)	
		POM-D/PA6.6				PP/PA6.6				POM-D/PA6.6		PP/PA6.6			**Carry (pcs)	**Return (pcs)
		Straight sections		Curve sections		Straight sections		Curve sections		kg/m	lb/ft	kg/m	lb/ft			
mm	in	N	lbf	N	lbf	N	lbf	N	lbf	kg/m	lb/ft	kg/m	lb/ft			
250	9.8	10000	2248	2440	549	5000	1124	1440	324	2.5	1.65	1.5	1.01	2	2	2
326	12.8	13040	2931	2440	549	6520	1466	1440	324	3.2	2.15	2.0	1.31	3	3	2
403	15.9	16120	3624	3110	699	8060	1812	1960	441	3.9	2.65	2.4	1.63	3	3	2
479	18.9	19160	4307	3110	699	9580	2154	1960	441	4.7	3.15	2.9	1.93	5	4	2
555	21.9	22200	4991	3110	699	11100	2495	1960	441	5.4	3.66	3.3	2.24	5	4	2
631	24.8	25240	5674	3110	699	12620	2837	1960	441	6.2	4.16	3.8	2.54	5	5	3
708	27.9	28320	6366	3110	699	14160	3183	1960	441	6.9	4.66	4.2	2.85	5	5	3
784	30.9	31360	7050	3110	699	15680	3525	1960	441	7.7	5.16	4.7	3.16	7	6	3
860	33.9	34400	7733	3110	699	17200	3867	1960	441	8.4	5.66	5.2	3.47	7	6	3
936	36.9	37440	8417	3110	699	18720	4208	1960	441	9.2	6.16	5.6	3.77	7	7	4
1013	39.9	40520	9109	3110	699	20260	4554	1960	441	9.9	6.67	6.1	4.08	7	7	4
1089	42.9	43560	9792	3110	699	21780	4896	1960	441	10.7	7.17	6.5	4.39	9	8	4

Additional non-standard belt widths are available in steps of 25.4 mm (1.00 in).  
 General belt tolerance is +0/-0.4% at 23°C/73°F. For exact belt width contact Customer Service. Non standard belt width on request.  
 \*Max. Load per Drive Sprocket. Belt material: POM-D 2500 N (562 lbf), PP 1200 N (270 lbf).  
 \*\*Max. Spacing between wear strips, Carry: 152.0 mm (6.00 in); Return: 304.0 mm (12.00 in).  
 \_\_\_\_\_ = Single Link



STANDARD

SIDE FLEXING

PITCH 50.8 MM/2.00 IN

## Accessories

### Rubber Top

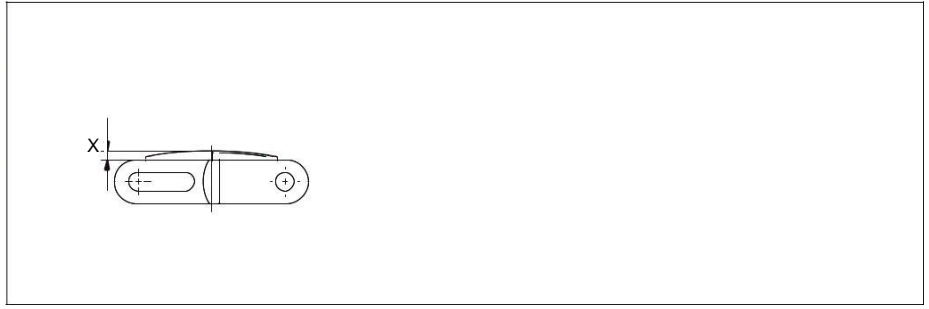
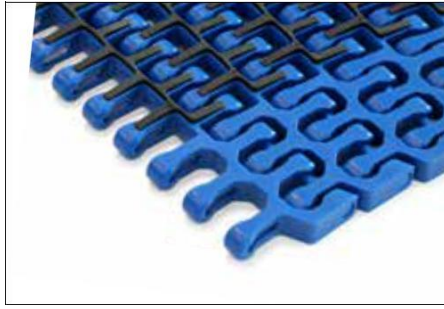

Type	Belt material & color	Rubber material, hardness & color	X	
			mm	in
Curved	PP <b>B</b>	TPE-S Shore A60 <b>K</b>	3.0	0.12

uni Flex L-ASB Rubber Top R1.6: Indent min. 97.0 mm (3.82 in) and Increment 25.4 mm (1.00 in).

## Accessories

### Side Guard Closed

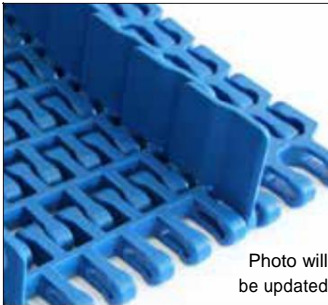
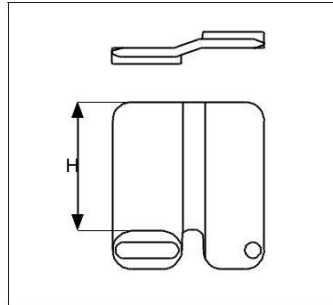

Photo will be updated



### Side Guard Open

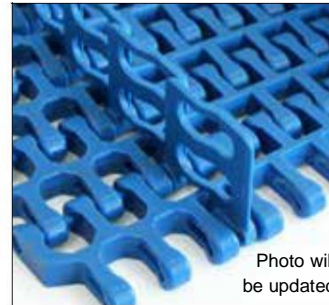
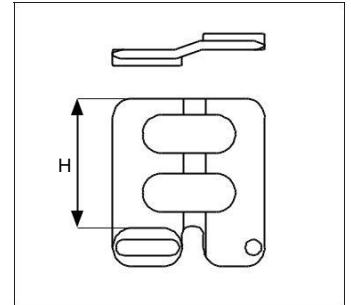
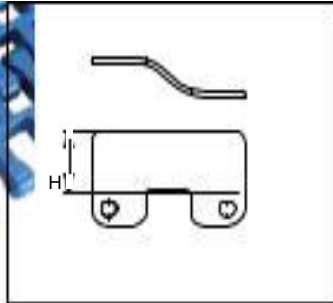

Photo will be updated



### Side Guard Outside Closed



Type	Material & color	H	
		mm	in
Side Guard Closed	POM-D <b>B</b>	10.0	0.39
		25.4	1.00
		50.0	1.97
Side Guard Open		50.0	1.97
Side Guard Outside Closed		25.4	1.00

Min. indent for Side Guard Closed and Side Guard Open: 55.0 mm (2.17 in) and Increment 25.4 mm (1.00 in).

Min/max indent for Side Guard Outside Closed: 10.0 mm (0.39 in).

Non Standard material and color: See uni Material and Color Overview.

## Accessories

### AmFlight

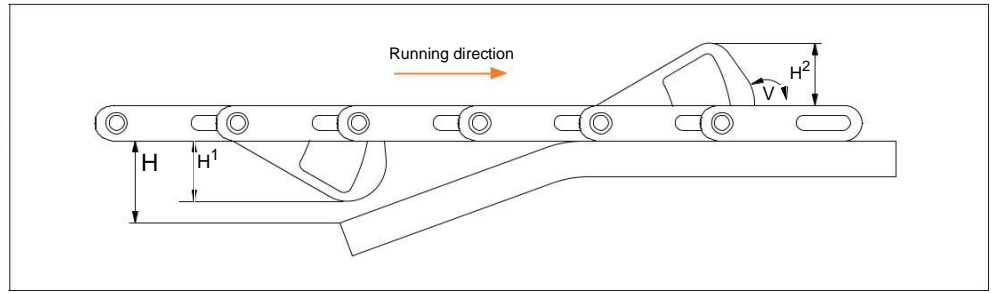
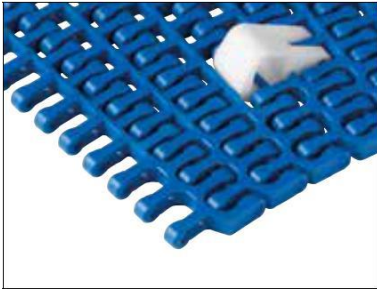

Type	Material & color	H	H <sub>1</sub>		H <sub>2</sub>		V
			mm	in	mm	in	
Push	PE <span style="border: 1px solid black; padding: 0 2px;">W</span>	H > H <sub>1</sub>	25.4	1.00	26.0	1.02	125

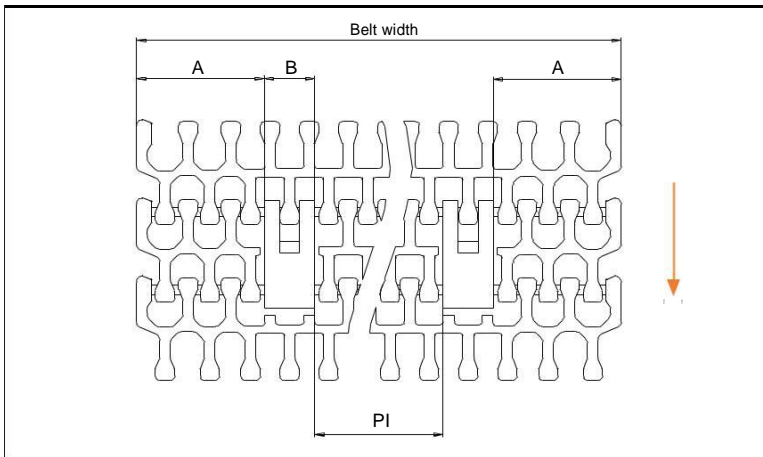

	mm	in
<b>A min</b>	83.0	3.27
<b>B</b>	33.0	1.30
<b>PI min</b>	68.5	2.70

Increment: 25.4 mm (1.00 in).

### Design Guidelines

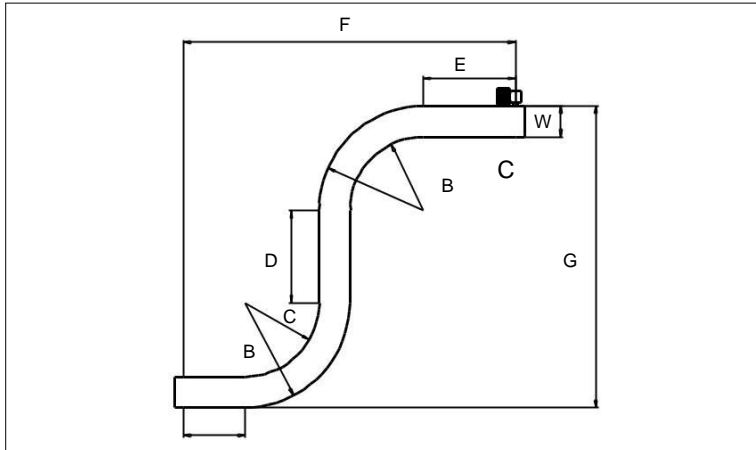

	uni Flex L-ASB R2.2	uni Flex L-ASB R1.6 (inside)
<b>A</b>	min. 1.5 x W	min. 1.5 x W
<b>B</b>	min. 3.2 x W	min. 2.6 x W
<b>C</b>	min. 2.2 x W	min. 1.6 x W
<b>D</b>	min. 2.0 x W	min. 2.0 x W
<b>E</b>	min. 2.0 x W	min. 2.0 x W
<b>F</b>	min. 8.9 x W	min. 7.7 x W
<b>G</b>	min. 8.4 x W	min. 7.2 x W

uni Flex L-ASB 47% Open Radius 1.6 can not be used in conveyors with both left and right turning curves. All curves have to turn in the same direction. For min. conveyor dimensions please refer to sketch and diagram.

## Sprocket

No. of teeth	Bore size							Overall		Pitch		Hub		Dimension		Dimension		Singlerow/Two way	MachinedPA6 N
	Pilot Bore	inmm	001.425.	30.0 181.	251.831.	501.138.	40.0 571.	502.563.	mm	in diameter	mm	in diameter	mm	in diameter	mm	in A	mm		
Z08	✓		●	●				134.6	5.30	131.5	5.18	107.6	4.23	54.4	2.14	74.9	2.95	✓	■
Z10	✓		●	●	●			168.3	6.63	164.0	6.46	141.3	5.56	71.4	2.81	90.8	3.57	✓	■
Z12	✓		●	●	●	●		203.5	8.01	196.5	7.74	176.5	6.94	88.2	3.47	106.8	4.20	✓	■
Z15	✓		●	●	●	●	■	253.4	9.98	245.4	9.66	226.4	8.91	113.2	4.46	131.0	5.16	✓	■

■ Machined sprocket ● Machined sprocket

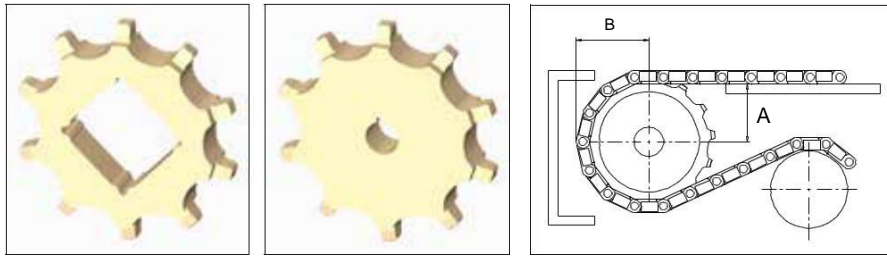

Non standard material and color: See uni Material and Color Overview.

Other sprocket sizes are available upon request  
 Two-part sprocket are available upon request  
 Other bore sizes are available upon request  
 uni Retainer Rings: See uni Retainer Ring data sheet  
 Width of tooth = 15.0 mm (0.59 in)  
 Width of sprocket = 30.0 mm (1.18 in)

Max. load per sprocket shown does not take bore size into account.  
 Please also ensure that sufficient size shaft is chosen for corresponding load.

For correct sprocket position: See uni Assembly Instructions for uni Flex L-ASB.  
 For more detailed sprocket information, contact Customer Service.